

# freedomRail®

## Installation Instructions Profile Collection

### Tools Required:

- Drill with 5/16" bit
- Level
- Tape Measure
- Pencil
- Phillips Driver bit

&

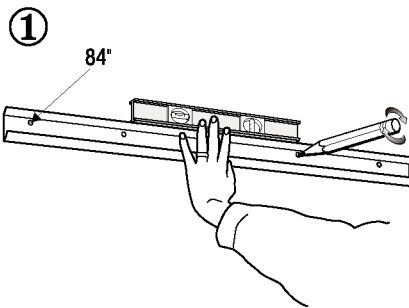
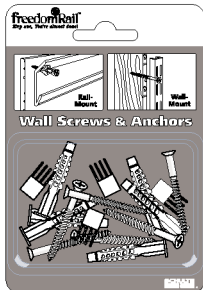

Recommended height for the Hanging Rail is 84" (typical door height). It can also be mounted at the ceiling or a special purpose height of your choosing.

Measure up from floor to 84" and mark. Position holes on Rail at mark. Level Rail and mark hole locations. 84" is the recommended height

NOTE: Rails **do not** need to be mounted to studs for maximum system strength.

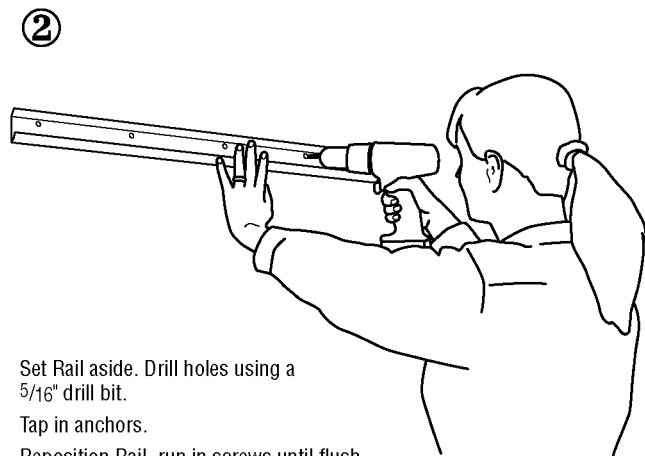

Set Rail aside. Drill holes using a 5/16" drill bit.

Tap in anchors.

Reposition Rail, run in screws until flush - then give power drill a good burst or two (or 4 to 6 complete rotations) to pull up anchor.

It's okay if screw overtightens.

③

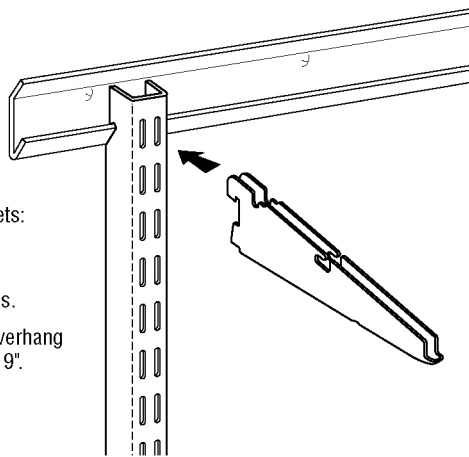

Recommended spacing for Hanging Uprights and Brackets:  
every 36" for clothes closets  
every 30" for pantries  
every 24" for very heavy loads.

NOTE: Profile shelves may overhang Uprights and Brackets up to 9".

④

Insert rod Clips. You'll feel the Rod Clips lock into place in this 2 step procedure.

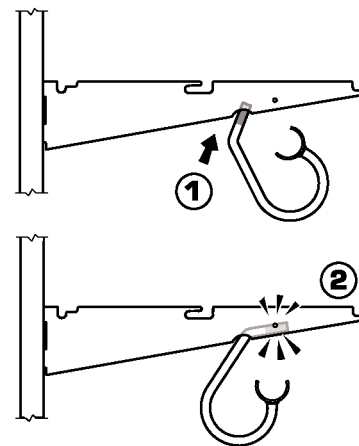

⑤

Snap Shelves into place.

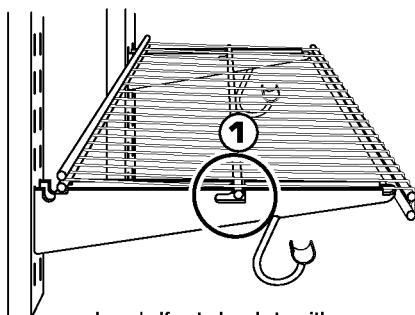

Lay shelf onto brackets with center support rod positioned in center bracket notch as shown ①.

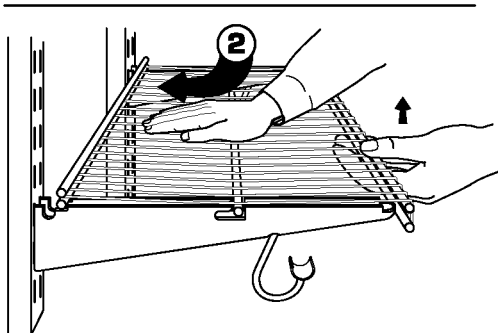

Push down and maintain pressure on center of shelf. Then lift front edge and slide shelf back ②. Shelf will snap into place.

⑥

Insert Rod Stops into ends of Chrome Rods.



Then turn clockwise until Rod Stop is tightened flush with Chrome Rod.

Lastly, lay Chrome Rod into the Rod Clip Saddle. Applying a moderate amount of pressure will securely lock the Rod in place.

(You will still be able to lift out the Rod should you decide to rearrange your configuration.)

